

Appendix B

**AFM Corporation
Fire Rated Assembly Details**

AFM Assembly 1 (1 Hour Fire Rated Assembly) (Formerly U534)

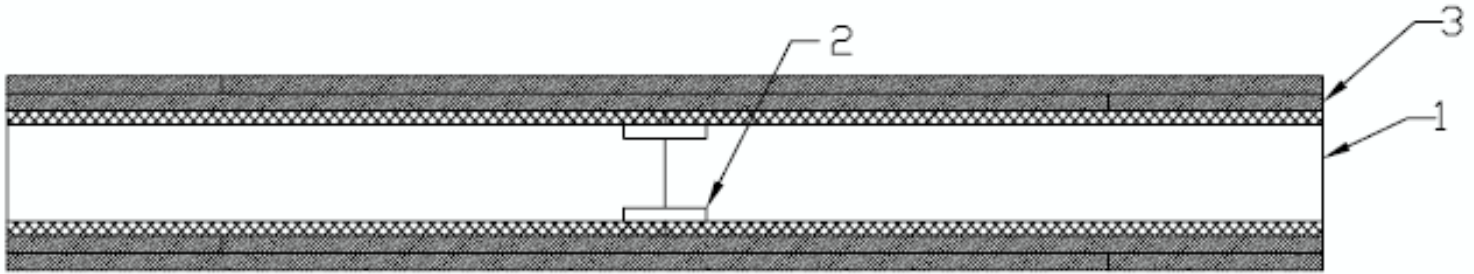

1. Panels - R-Control SIPs consisting of a polystyrene foamed plastic core faced on both surfaces with min 7/16 in. thick oriented strand board. Min 3-3/8 in. thick polystyrene core. R-Control SIPs loaded to 1800 lb. per linear foot.

2. Splines - Nom 4 in. wide by 7/16 in. thick oriented strand board splines installed between vertical joints, in pre-cut channels in the Panels (Item 1). Splines secured to face in contact with oriented strand board with R-Control Do-All-Ply and 1-5/8 in. long Type S steel screws spaced 6 in. OC along the edges of each adjoining face.

3. Gypsum Board - 5/8 in. thick, 4 ft wide, Type X applied vertically in two layers. First layer installed with 1-5/8 in. long Type S steel screws spaced 24 in. OC vertically and 16 in. OC horizontally. First layer vertical joints offset min 16 in. from vertical spline joints of Panels (Item 1). Second layer installed with 2 in. long Type S steel screws spaced 12 in. OC vertically, offset 12 in. from first layer screws, and 16 in. OC horizontally, offset 8 in. from first layer screws. Second layer vertical joints offset min 16 in. from first layer vertical joints. Outer layer wallboard joints covered with joint tape and joint compound. Screw heads on outer layer of wallboard covered with joint compound.

4. Plates (Not Shown) - Nom 2 in. thick (width determined by panel thickness) No. 2 lumber installed at top and bottom of Panels (Item 1) in pre-cut channels. Plates secured with 8d box nails spaced 8 in. OC along the edges of both faces and R-Control Do-All-Ply to faces in contact with oriented strand board and on the face in contact with the polystyrene core.

AFM Assembly 2 (1 Hour Fire Rated Assembly) (Formerly U535)

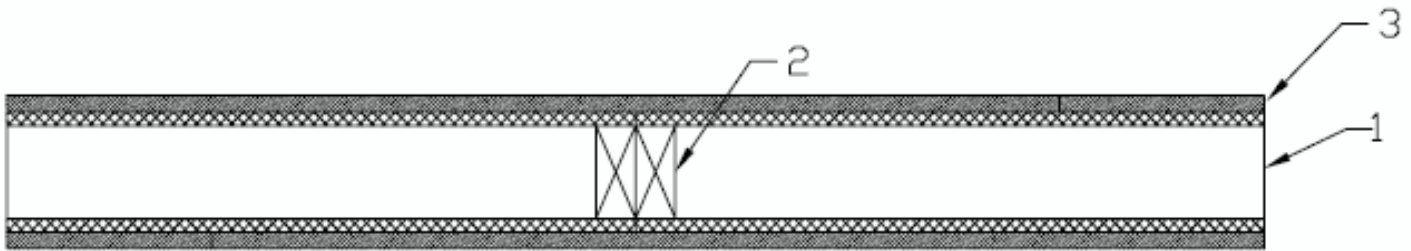

1. Panels - R-Control SIPs consisting of a polystyrene foamed plastic core faced on both surfaces with min 7/16 in. thick oriented strand board. Min 5-3/8 in. thick polystyrene core. R-Control SIPs loaded to 1800 lb. per linear foot.

2. Splines - Two Nom. 2 by 6 in. thick No. 2 lumber installed in Panels (Item 1) in pre-cut channels. End stud and bearing plate secured to the oriented strand board with 1-5/8 in. long ring shank nails spaced 12 in. OC along the edges on both faces.

3. Gypsum Board - 5/8 in. thick, 4 ft. wide, applied vertically installed with 1-5/8 in. long high/low bugle-head steel screws spaced 8 in. OC along the edges and 12 in. OC in the field. Vertical joints over vertical joints of Building Units* (Item 1). Gypsum Board joints covered with joint tape and joint compound. Screw heads covered with joint compound.

AMERICAN GYPSUM CO - Type AG-C

CANADIAN GYPSUM COMPANY - Type C.

LAFARGE NORTH AMERICA INC - Types LGFC-C/A.

TEMPLE-INLAND FOREST PRODUCTS CORP - Type TG-C

UNITED STATES GYPSUM CO - Type C.

USG MEXICO S A DE C V - Type C.

4. Plates (Not Shown) - Nom 2 in. thick (width determined by panel thickness) No. 2 lumber installed at top and bottom of Panels (Item 1) in pre-cut channels. Plates secured with 8d box nails spaced 8 in. OC along the edges of both faces and R-Control Do-All-Ply to faces in contact with oriented strand board and on the face in contact with the polystyrene core.

AFM Assembly 3 (1 Hour Fire Rated Assembly) (Formerly P517)

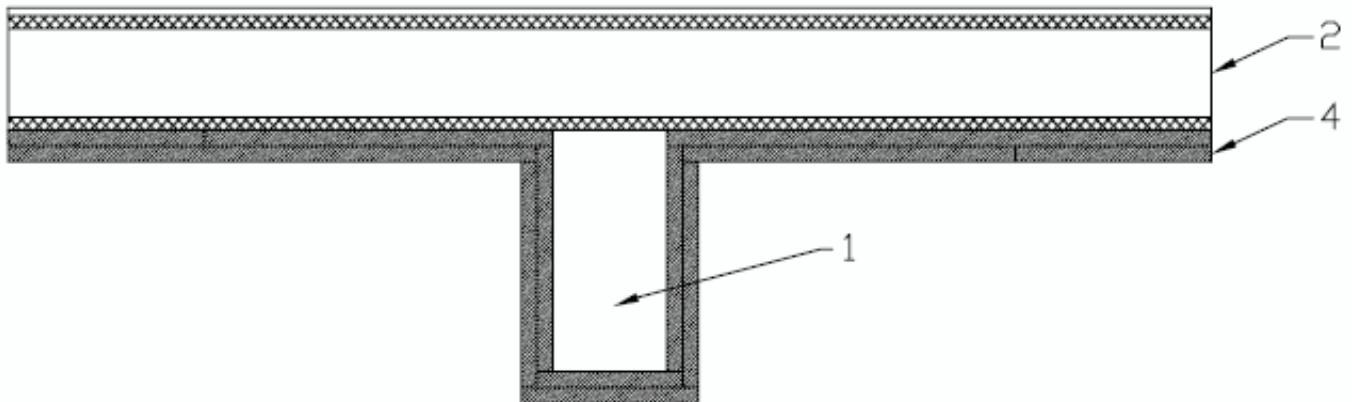

1. Wood Beam - Min 4-1/2 in. wide by 9-1/2 in. deep size wood beam spaced in accordance with manufacturer's specifications.

2. Panels - R-Control SIPs consisting of a polystyrene foamed plastic core faced on both surfaces with min 7/16 in. thick oriented strand board. Min 3-3/8 in. thick polystyrene core.

3. Splines (not shown) - Nom 2 in. thick wood members, installed in accordance with manufacturer's design specifications.

4. Gypsum Board - Min 5/8 in. thick, 4 ft wide, Type X. For ceiling, two layers of 5/8 in. thick by 48 in. wide sheets installed with long dimension perpendicular to wood beams. Inner layer attached to Panels using 1-1/4 in. long Type S bugle-head steel screws spaced 8 in. OC along the joints and located 1/2 in. from the edges. Joints of inner layer of wallboard to be staggered from joints of panels. Outer layer attached to building unit using 2 in. long bugle-head steel screws spaced 8 in. OC and located 3/4 in. from the edge, and 12 in. OC in the field. Joints of outer layer to be staggered from joints of inner layer. For beam two layers of 5/8 in. gypsum wallboard fastened to wood beam using 1-1/4 in. long Type S bugle-head steel screws spaced 8 in. OC and outer layer fastened to wood beam using 2 in. long Type S bugle-head steel screws.

5. Joint System - (Not Shown) Outer wallboard joints covered with paper tape and joint compound. Screw heads covered with joint compound.

AFM Assembly 4 (1 Hour Fire Rated Assembly) (Formerly P822 / P839)

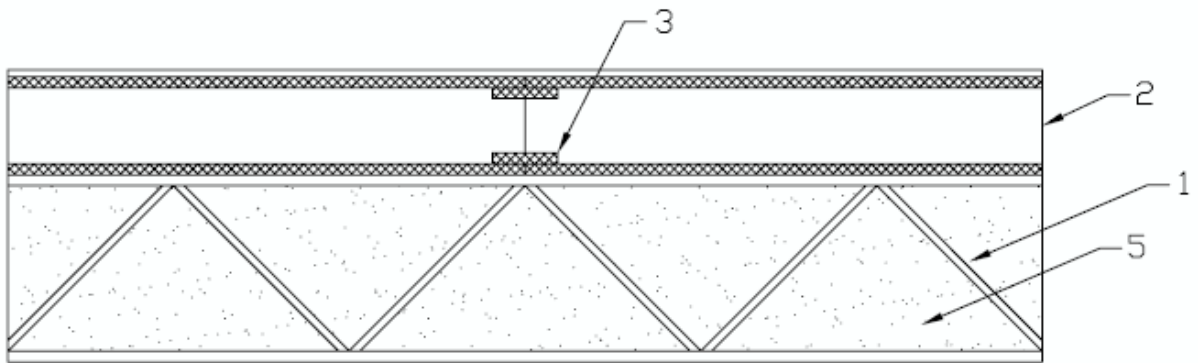

1. Steel Joist - Type 10K1 min size spaced in accordance with manufacturer's installation specifications.

2. Panels - R-Control SIPs consisting of a polystyrene foamed plastic core faced on both surfaces with min 7/16 in. thick oriented strand board. Min 3-3/8 in. thick polystyrene core.

3. Spline - Nom 4 in wide by 7/16 in. thick spline installed between the building units in accordance with building units manufactures installation instructions.

4. Metal Lath (not shown) - Diamond mesh 3/8 in. expanded galv steel weighing 3.4 lbs per sq yd. Secured to one side of joist using No. 20 SWG steel tie wire located at the midheight of every other web member. Additional lath, installed to bottom surface of building units and secured by means of 1 in. wide by 1-1/2 in. long staples spaced 7 in. OC.

5. Spray-Applied Fire Resistive Materials - Applied to wetted surfaces of steel joist bottom surface of building unit and metal lath which are free of dirt, oil or loose scale by spraying with water to achieve a min 2-1/4 in. thickness. Min avg density of 13 pcf with min ind density of 11 pcf for Types DC/F and II. Min avg density of 22 pcf with min ind density of 19 pcf for Type HP.

ISOLATEK INTERNATIONAL - Types DC/F, II or HP. Type EBS or Type X adhesive/sealer, optional.

5A. Spray-Applied Fire Resistive Materials - Applied to wetted surfaces of steel joist bottom surface of building unit and metal lath which are free of dirt, oil or loose scale by spraying with water to achieve a min 2-1/4 in. thickness. Min avg density of 13 pcf with min ind density of 11 pcf for Type PBS2.

CAFCO FRANCE - Type PBS2